

DISPLAY-BOARD

Page	Description
1	DISPLAY-CONTROLLER
2	BLUETOOTH
3	POWER SEQUENCING
4	LED, KEYBOARD-CONNECTION

© Infineon Technologies AG 2006.
All Rights Reserved.

LEGAL DISCLAIMER:

THE INFORMATION GIVEN IN THIS DOCUMENT IS GIVEN FOR ILLUSTRATING PURPOSES ONLY. THE RECIPIENT OF THIS DOCUMENT MUST VERIFY ANY FUNCTION DESCRIBED HEREIN IN THE REAL APPLICATION. INFINEON TECHNOLOGIES HEREBY DISCLAIMS ANY AND ALL WARRANTIES AND LIABILITIES OF ANY KIND (INCLUDING WITHOUT LIMITATION WARRANTIES OF NON-INFRINGEMENT OF INTELLECTUAL PROPERTY RIGHTS OF ANY THIRD PARTY) WITH RESPECT TO ANY AND ALL INFORMATION GIVEN IN THIS DOCUMENT.

DISPLAY-BOARD

Title		
INCA-IP2 Reference system		
Size	Document Number	Rev
A	release 1.0	1.1
Date:	Thursday, October 19, 2006	Sheet 0 of 15

DISPLAY-BOARD

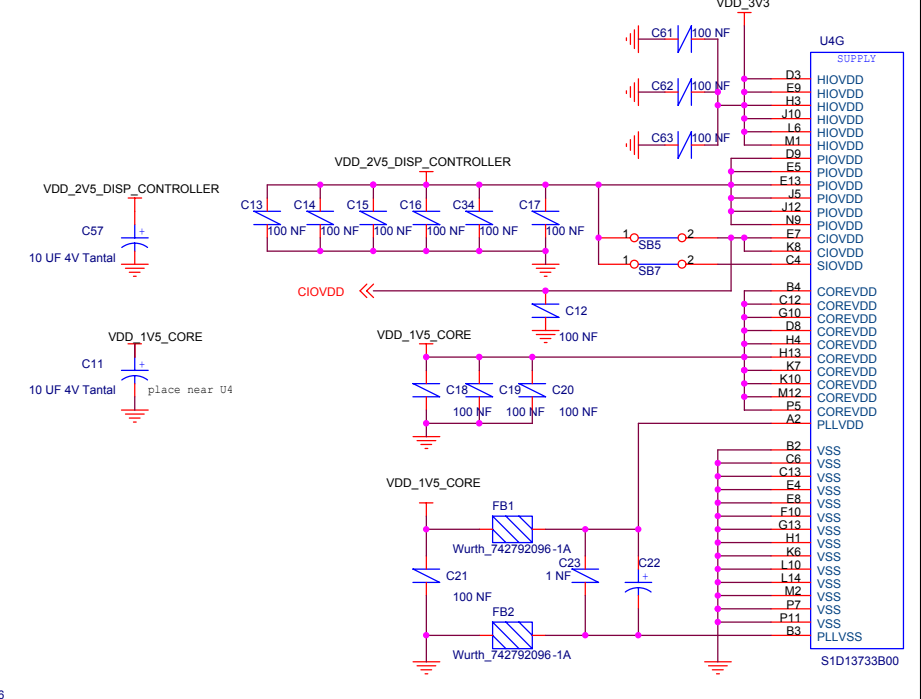
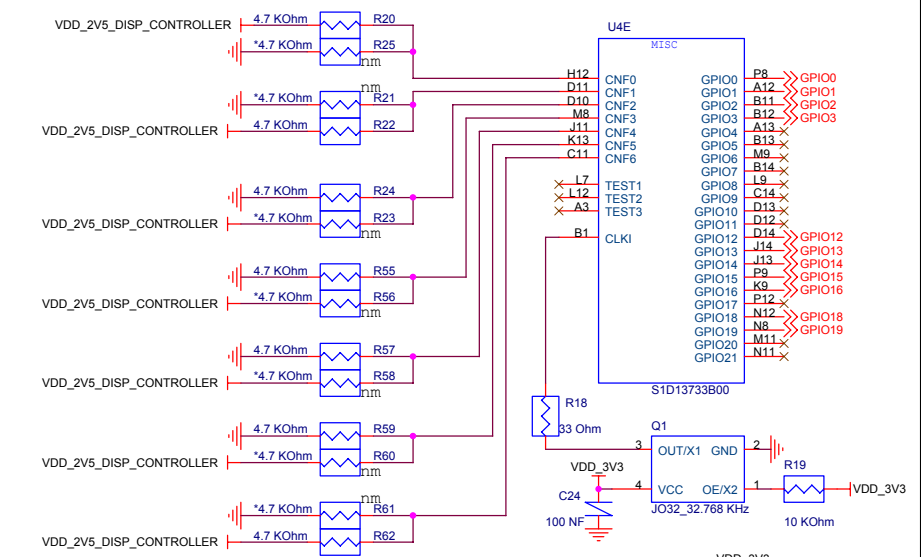
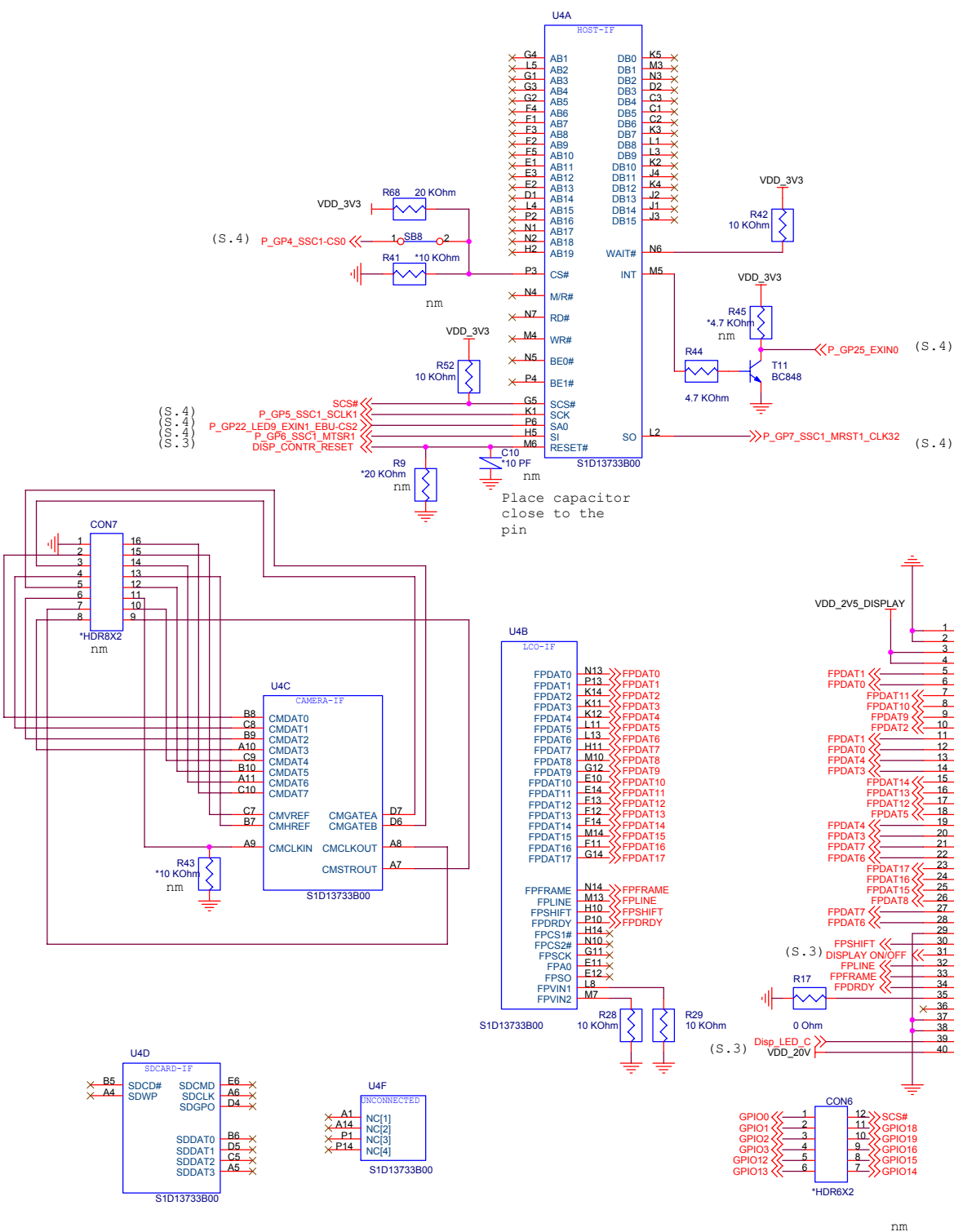

DISPLAY-BOARD

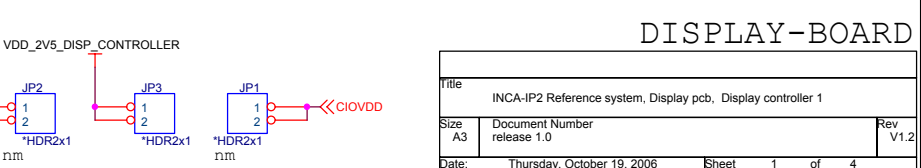

Title			INCA-IP2 Reference system, Display pcb, Display controller 1		
Size	Document Number				Rev
A3	release 1.0				V1.2
Date:	Thursday, October 19, 2006	Sheet	1	of	4

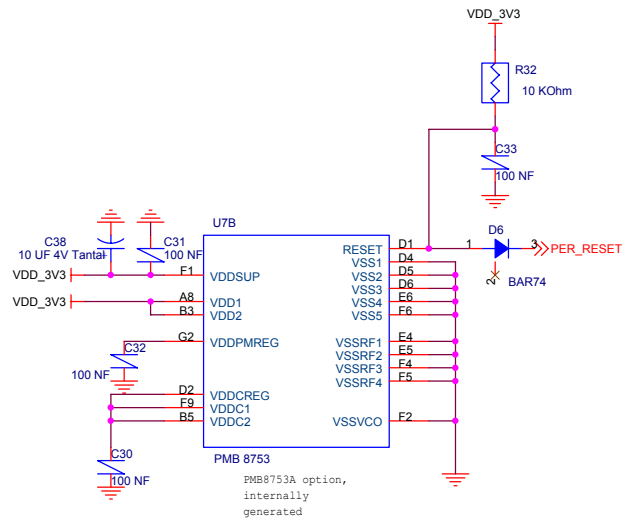
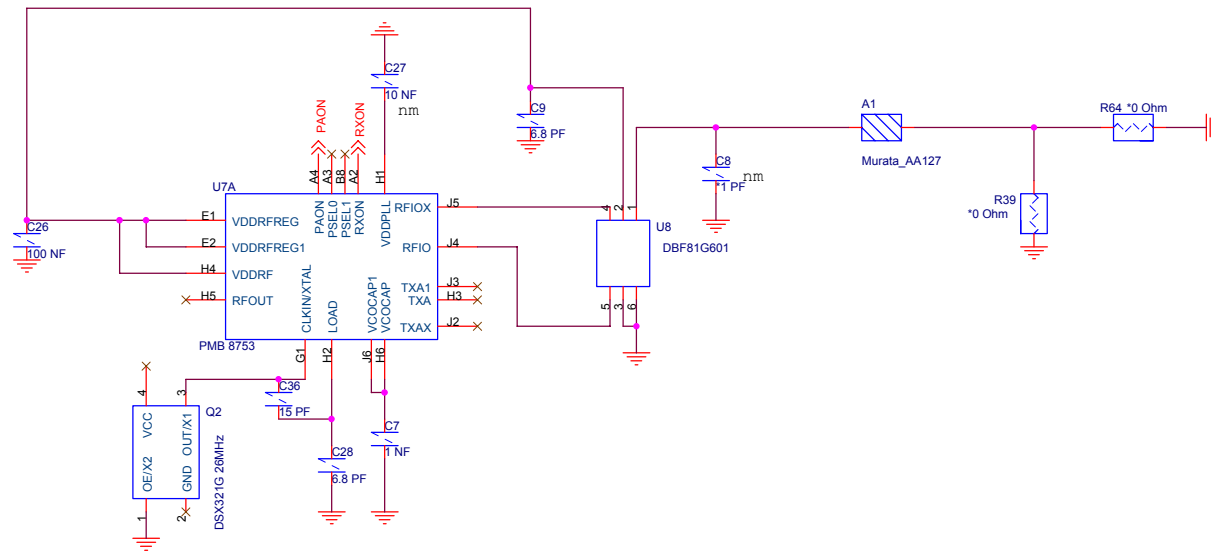

PMB8753A option, internally generated

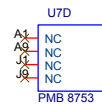

(S. 4)

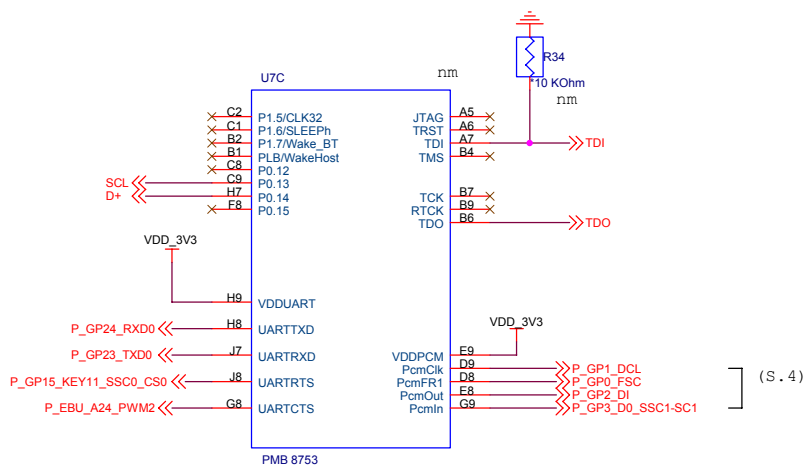

(S. 4)

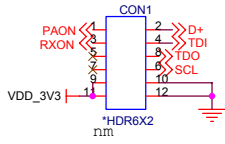

Title INCA-IP2 Reference system, Display pcb, Blue Moon		
Size A3	Document Number release 1.0	Rev V1.2
Date: Thursday, October 19, 2006	Sheet 2	of 4

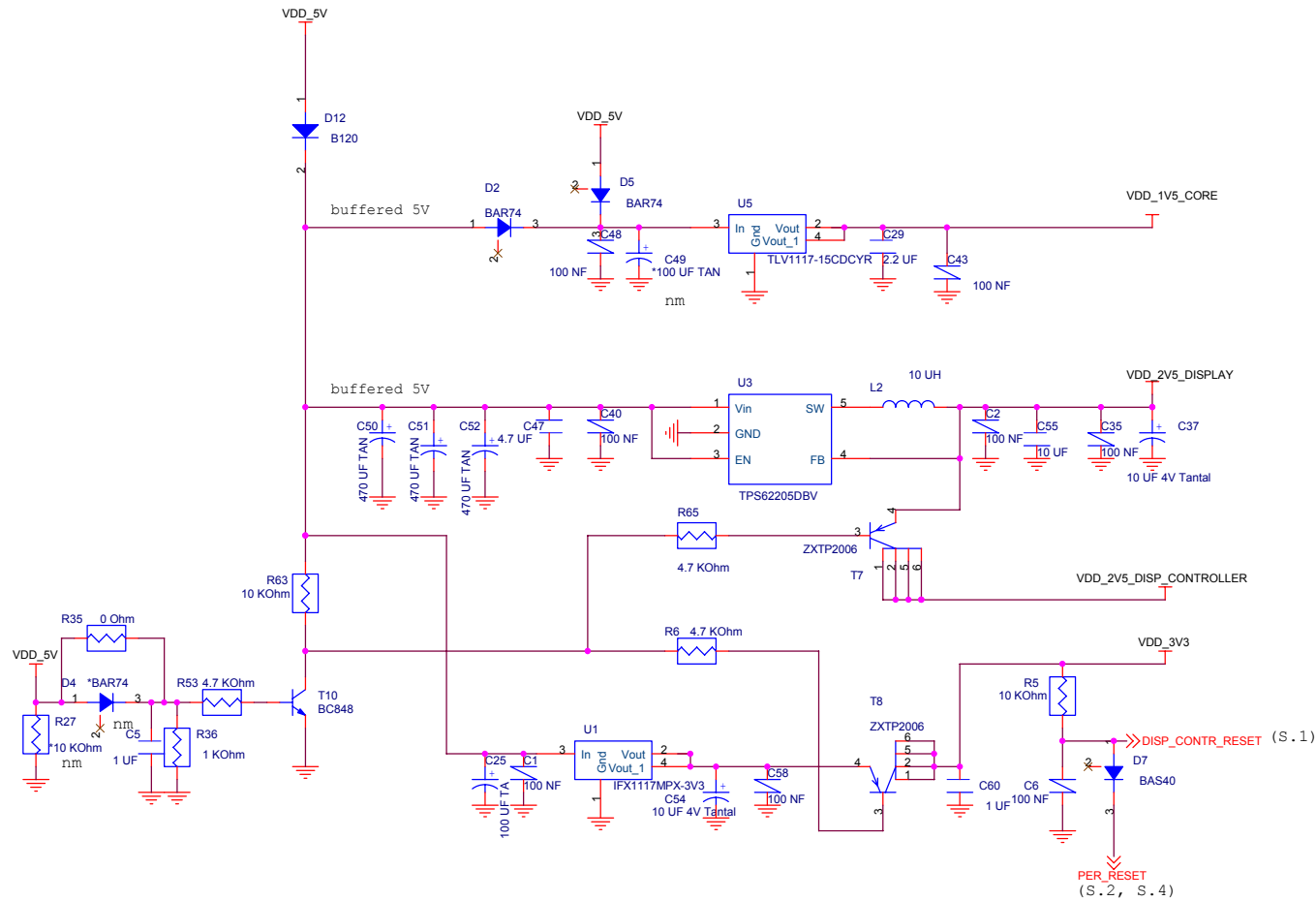

power sequence

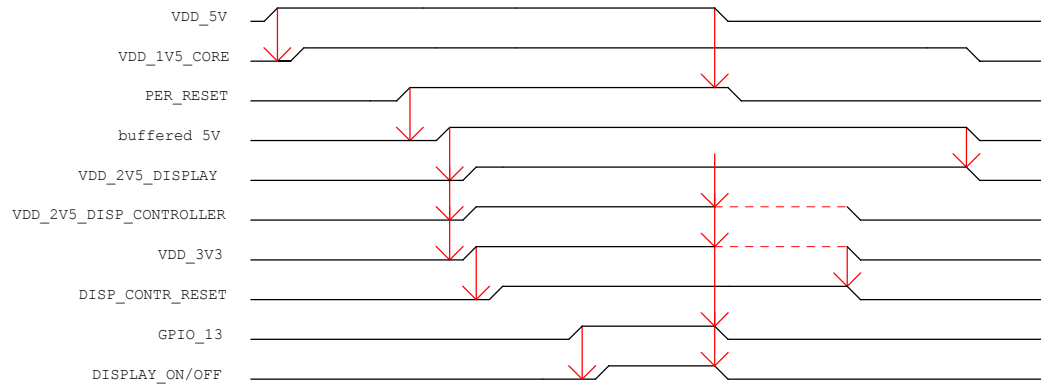

power for light of display

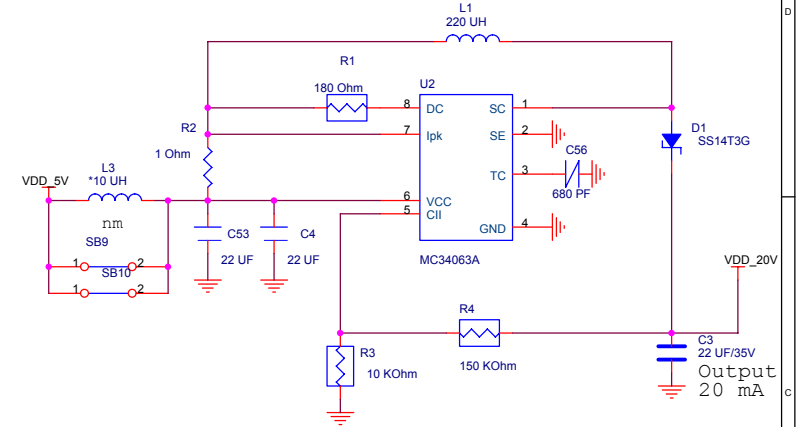

dimmer of the display

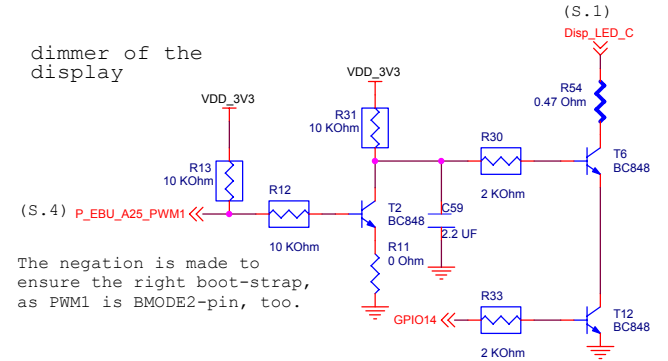

The negation is made to ensure the right boot-strap, as PWM1 is BMODE2-pin, too.

display activation

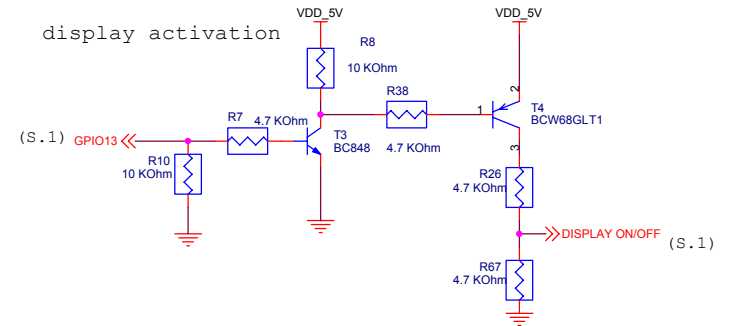

Title INCA-IP2 Reference system, Display pcb, Power		
Size A3	Document Number release 1.0	Rev 1.2
Date: Thursday, October 19, 2006	Sheet 3	of 4

DISPLAY-BOARD

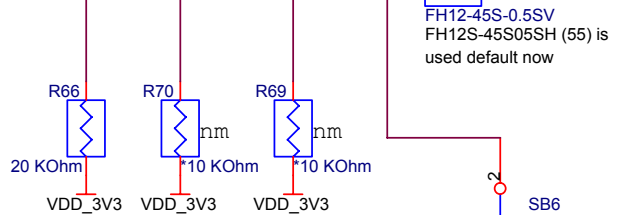
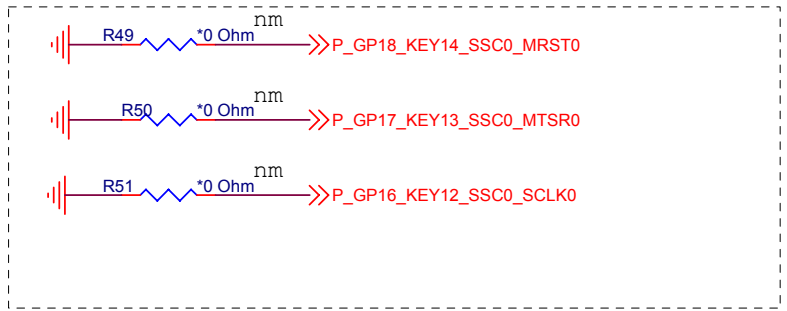
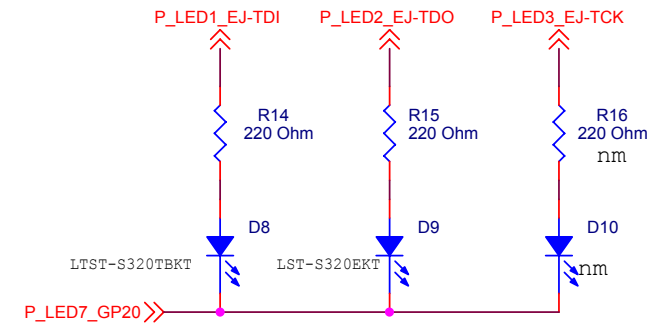
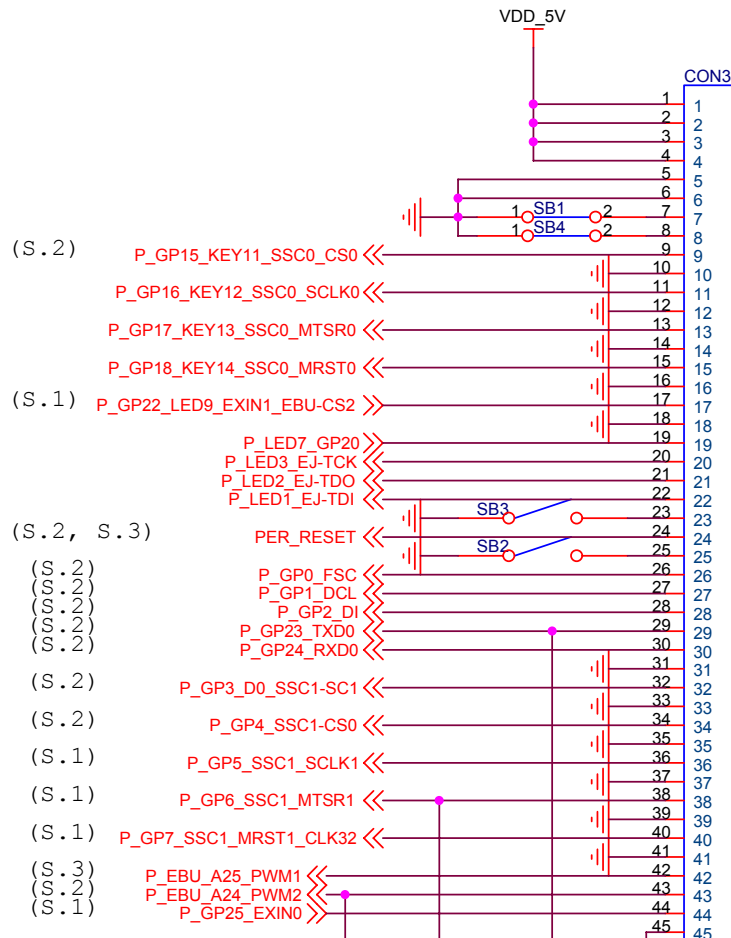

This resistors are for board identification.
 The counterparts are on the Keyboard PCB

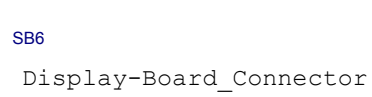

DISPLAY-BOARD

Title		
INCA-IP2 Reference system, Display pcb, Kbd pcb Connector, LED		
Size	Document Number	Rev
A4	release 1.0	V1.2
Date:	Thursday, October 19, 2006	Sheet 4 of 4